

ODYSSEY[®] BATTERY

DINC size now available with

**ODYSSEY[®]
CONNECT** 
BATTERY MONITORING SYSTEM



100%

STRONGER
FOR LONGER LIFE*

30%

MORE DEEP-CYCLE
CAPABILITY*



215Ah 1250A CCA

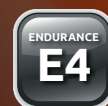

AGM² TPPL Technology is Here

Today's professional vehicles are more demanding, with driver systems and hotel functions now requiring higher performance than conventional batteries were ever designed for.

ODYSSEY[®] AGM² batteries with TPPL (Thin Plate Pure Lead) technology provide the solution that can meet these new high power consumption demands.

With the DINC size now available with ODYSSEY[®]CONNECT[™] and CONNECT Battery Monitoring App, you can take control, giving you real-time data to be ahead of any issues and keep you on the road.



To find out more visit eu.odysseybattery.com



EnerSys[®]
Power/Full Solutions

NEW ODYSSEY® Battery DIN Series line up for Heavy Duty vehicles

To meet the needs of today's heavy and professional vehicles EnerSys® has developed a range of ODYSSEY® battery DIN sizes. So, whether it's massive cranking power, servicing demanding hotel or auxiliary loads, or managing in extreme cold or heat there will be a battery to provide the solution.

Optimised AGM² TPPL Range - DINC & ACEDINC

These batteries have been engineered and designed to match the rigorous demands of heavy duty vehicle fleets – creating a battery with superb 'sprint' starting ability combined with exceptional deep cycle 'marathon' performance.

Available with or without revolutionary ODYSSEY®CONNECT™ technology, you can choose whether you require a 'Connected' solution using the dedicated Battery Monitoring App or not.

- ✓ Measures voltage and temperature
- ✓ Stores battery history, characteristics and state of health
- ✓ Communicates using Bluetooth® 4.1
- ✓ EnerSys® patented** technology
- ✓ App available on iOS and Android

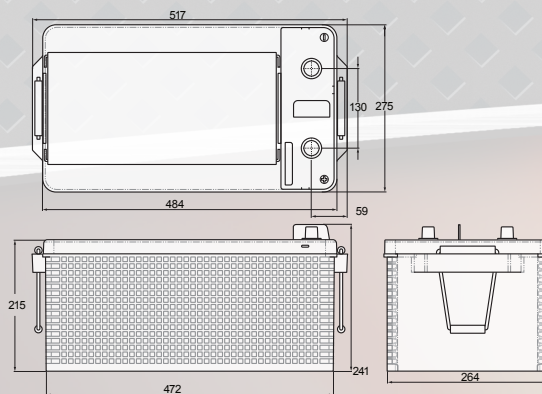

ODP-AGMDINC & ODP-ACEDINC

AGM² TPPL Range - DIN B & DIN C

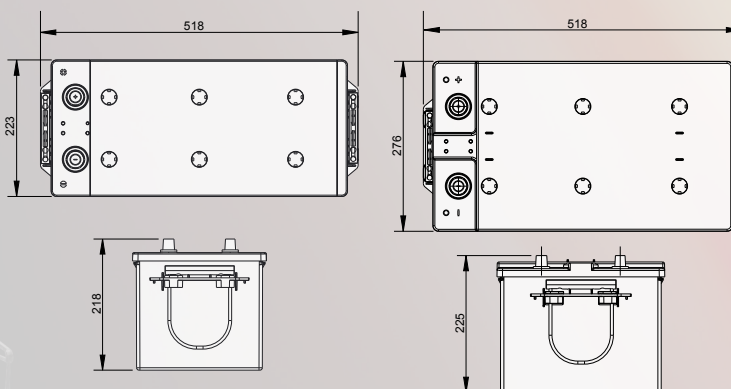

ODP-AGMDINB (629-DIN B-1300)

625-DIN C-1500

Model Name	Old Model Name	Voltage	20 Hr Rate	CCA	Length (mm)	Width (mm)	Max Height (mm)	Weight (kg)	Terminals	Country of Origin	Qty per Pallet
ODP-AGMDINB	629-DIN B-1300	12V	170Ah	1300A	518	223	218	53.3	SAE	FR	14
ODP-AGMDINC	New	12V	215Ah	1250A	517	275	241	64.7	SAE	FR	12
ODP-ACEDINC	New	12V	215Ah	1250A	517	275	241	64.7	SAE	FR	12
625-DIN C-1500	-	12V	220Ah	1500A	518	276	225	65.0	SAE	FR	12

All dimensions and capacities are nominal



EnerSys World Headquarters
 2386 Bernville Road
 Reading, PA 19605, USA

EnerSys EMEA
 EH Europe GmbH,
 Baarerstrasse 18,
 6300 Zug
 Switzerland

EnerSys Asia
 152 Beach Road,
 Gateway East Building #11-08,
 Singapore 189721

